

LiFePO4 Battery Specification

Model: TB-BL36100F-S110A



TOPBAND BATTERY CO.,LTD

Address: Topband Industrial Park,Liyuan Industrial Zone,Shiyan,Bao'an,Shenzhen, China,518108.

Web: www.topband.com.cn

Registered	He Yanrong	Customer	
Checked	Chen Xiaomin	Customer Model	
Approved	Yuan Zhiwei	Customer Reback:	
Issued Date	2018-2-7		
Issued Version	V00		

1. General Information

This specification defines the performance of rechargeable LiFePO₄ battery pack TB-BL36100F-S110A manufactured by TOPBAND BATTERY CO.LTD, describes the type, performance, technical characteristics, warning and caution of the battery pack.

2. Specification(@Battery initial Temp25±5°C)

NO.	Items	Criteria	Remarks
2.1	Rated Capacity	100Ah	
	Minimum Capacity	98Ah	@0.33C
2.2	Energy	3.84KWh	
2.3	Nominal Voltage	38.4V	
2.4	Outgoing Voltage	≥38.4V	
2.5	Internal resistance	≤25mΩ	
2.6	Limited charge voltage	43.8±0.2V	
2.7	Floating charge voltage	41.4±0.2V	
2.8	Standard charge current	50A	
2.9	Maximum charge current	50A	
2.10	Maximum discharge current	50A	
2.11	Pulse discharge current	300A/Continuous for 3s	
2.12	Discharge cut-off voltage	29~33V	
2.13	Dimension	Length: 520±3 mm	
		Width: 268±3 mm	
		Height: 222±3 mm	
2.14	Weight	Approx: 39±0.5Kg	
2.15	Operating Temperature	Charging: 0~45°C	
		Discharging: -20~60°C	
		Recommended operating temperature: 15°C~35°C	
2.16	Self-discharge rate	Residual capacity: ≤5%/month;≤50%/year	
2.17	Storage Temperature & Humidity Range	Less than 1 month: -20°C~45°C, 45%RH~75%RH	
		Less than 3 months: -10°C~35°C, 45%RH~75%RH	
		Recommended storage environment: 15°C~35°C, 45%RH~75%RH	
<p>Long time storage:</p> <p>If the battery need be stored for a long time, the voltage should be 39.6V (50%SOC), and stored in the condition as storage proposal. It need at least one charge & discharge cycle every six months.</p>			

3. Test Conditions

3.1 Standard Test Conditions

3.1.1 Unless otherwise specified, all performance tests is required conducted at temperature $25^{\circ}\text{C}\pm 2^{\circ}\text{C}$, Humidity less than 45%~75%RH.

3.1.3 Unless otherwise specified, the tested product is required unused within two month after outgoing.

3.2 Standard Charge Mode

"Standard Charge" means at $25\pm 2^{\circ}\text{C}$ charge to limit voltage with 1C constant current, then charge with constant voltage until current less than 0.02C.

3.3 Quick Charge Mode

"Quick Charge" means at $25\pm 2^{\circ}\text{C}$ charge to limit voltage with 1C constant current, then charge with constant voltage until current less than 0.02C.

3.4 Standard Discharge Mode

"Standard Discharge" means at $25\pm 2^{\circ}\text{C}$ discharge to the cut-off voltage with 1C current.

3.5 Quick Discharge Mode

"Quick Discharge" means discharge to the cut-off voltage with 1C current.

4. Product Performance

NO.	Items	Criteria		Testing method
4.1	Rated Capacity	100Ah		Rest for 1 hour after fully charged, then discharge with 0.33C current until the battery reaches the discharge cutoff voltage. Repeat above process for three times, if the discharge time is not less than 180 minutes, you can stop and define the Discharging current*time value (Ah) as battery capacity.
4.2	Minimum Capacity	98Ah		
4.3	Internal resistance	$\leq 25\text{m}\Omega$		50% battery SOC state frequency of 1 KHZ ac resistance tester
4.5	Cycle life (DOD100%)	≥ 2000 cycle		Discharge with the current of 0.33C until it can't discharge, and then rest it for 1h. Charge the battery following CC (1C)/CV (43.8V) mode to full capacity, and then rest it for 1h. Repeat above process until full charged capacity is no more than 80% of normal value. Accumulated times is defined as cycle life.
4.6	Discharge Temperature Characteristics	-20°C	$\geq 70\%$	At $25\pm 5^{\circ}\text{C}$ discharge the battery with the current of 0.33C to the cut-off voltage and record charge capacity. Store the battery at various temperatures for 2h and discharge the battery with 0.33C to the cut-off voltage.
		-0°C	$\geq 80\%$	
		25°C	$\geq 100\%$	
		55°C	$\geq 95\%$	
4.7	Charge Retention ability	Residual capacity $\geq 80\%$		Charge the battery to full capacity and store it for 28days, and then discharge it with 0.33C to the

		Recovery capacity \geq 90%	cut-off voltage.
4.8	Communication function	Bluetooth	Through APP, user can read the battery system information such as voltage, current, SOC, temperature, etc.

5. Protective circuit specification

The batteries are supplied with a LiFePO₄ Battery Management System (BMS) that can monitor and optimized each single prismatic cell during charge & discharge, to protect the battery pack overcharge, over discharge, short circuit. Overall, the BMS helps to ensure safe and accurate running.

NO.	Items	Content	Specification
5.1	Over charge	Over-charge protection for each cell	3.80 \pm 0.05V
		Over-charge release for each cell	3.60 \pm 0.05V
		Over-charge release method	Under the release voltage
5.2	Over discharge	Over-discharge protection for each cell	2.50 \pm 0.05V
		Over-discharge release for each cell	2.80 \pm 0.05V
		Over-discharge release method	Charging recovery
5.3	Over current	Discharge over current protection 1	60 \pm 5A, delay 28~32S
		Discharge over current protection 2	350 \pm 30A, delay 1.5~2.5s
		Over current release method	8s after cutoff the load.
5.4	Short	Do not short-circuit the electrodes	5s after cutoff the load.
5.5	Battery temperature	Charge over temperature	Protection @55 \pm 5 $^{\circ}$ C
			Release @45 \pm 5 $^{\circ}$ C
		Discharge over temperature	Protection @65 \pm 5 $^{\circ}$ C
			Release @55 \pm 5 $^{\circ}$ C
5.6	Static power	\leq 200uA	

6. Dimensional Drawing (Unit: mm)

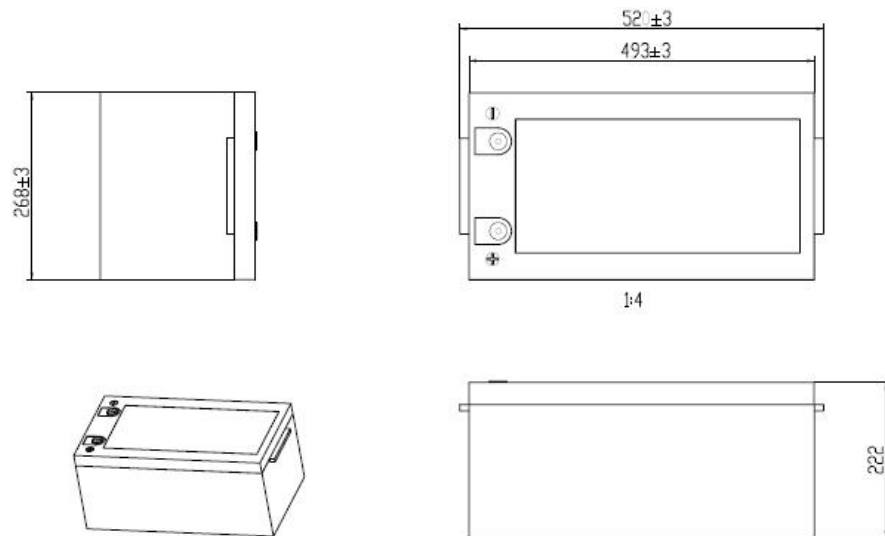

7. Transportation

- * Based on the character of cell, proper environment for transportation of LiFePO₄ battery pack need to be created to protect the battery.
- * Battery should be stayed in the warehouse 15°C ~ 35°C where it's dry, clean, shade, and well-ventilated.
- * The battery should be stored in 50% SOC during transportation.
- * The battery need to be charged every 6 months if out of use
- * Keep the battery against dropping, turning over and serious stacking during loading.

8. Warning & Tips

Please read and follow the specification and caution remarks on battery surface before use the battery. Improper use may cause heat, fire, rupture, and damage or capacity deterioration of the battery. TOPBAND NEW ENERGY CO., LTD. Describes is not responsible for any accidents caused by the usage without following our specification.

- ◇ The battery must be far away from heat source, high voltage, and avoid to be exposed in sunshine for long time.
- ◇ Never throw the battery into water.
- ◇ Do not put the battery in a charger or equipment with wrong terminals connected.
- ◇ Never connect the positive and negative of battery with metal.
- ◇ Avoid excessive physical shock or vibration. don't hit, fall, stamp on the battery
- ◇ Without the permission of the manufacturer and guidance, forbidden to remove or to assemble the battery
- ◇ Do not use the battery mixed with other different manufacturer, type, or model batteries.
- ◇ Keep the battery against high temperature. Otherwise it will cause battery heat, get into fire or lose some function and reduce the life.
- ◇ When battery run out of power, please charge your battery timely (≤ 15 day).
- ◇ Please use the matched or suggested charger for this battery.
- ◇ If battery emits peculiar smell, heating, distortion or appears any abnormality during working or storage,

please stop using and take it out from device.

- ✧ If the battery leaks and get into the eyes or skin, do not wipe, instead, rinse it with clean water and see doctor immediately.
- ✧ Please far away from children or pets.
- ✧ Do not put disuse battery into a fire or water.
- ✧ Series connection of this battery pack is prohibited.

9. Battery operation instruction

Charge and discharge

1. Charging current: Do not surpass the largest charging current that specification stipulated.
2. Charging voltage: Do not surpass the highest limited voltage that specification stipulated.
3. Charging temperature: Within temperature scope that specification stipulated.
4. Charge with constant current, then with the constant voltage, no reverse charge, which is dangerous
5. Special note: Short time doesn't affect the use of the battery overcharge too, but for a long period of time over discharge or over charge can affect the function of the battery failure, or the battery can't use permanent, appear serious safety hazards, and need long time floating please use the recommended floating model specification. Battery when not in use for a long time, because of its own self-discharge characteristics can also cause discharge, to prevent the occurrence of a discharge, battery should maintain a certain capacity; maintain the voltage at 50% state of SOC.

10. Other Chemical Reaction

Because batteries utilize a chemical reaction, battery performance will deteriorate over time even if stored for a long period of time without being used. In addition, if the various usage conditions such as charge, discharge, ambient temperature, etc. are not maintained within the specified ranges, the life expectancy of the battery may be shortened or the device in which the battery is used may be damaged by electrolyte leakage. If the discharge time is much shorter than the normal after full charged, even battery is charged correctly, and this may indicate it is time to change the battery.